

OF FLUTES _____
 HELIX ANGLE _____
 HAND OF CUT _____
 COATING _____
 BACKTAPER _____

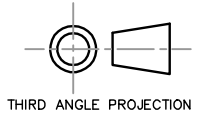

TANG YES NO
 COOLANT THRU YES NO

STANDARD TOLERNACES UNLESS OTHERWISE SPECIFIED	
0.00	±0.06
0.000	±0.005
0.0000	±0.0005
ANGLES	±2°

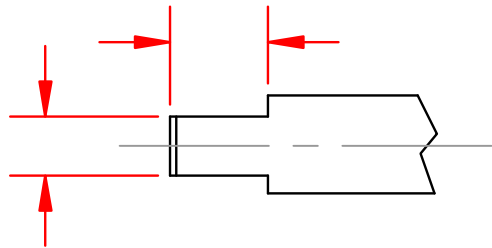
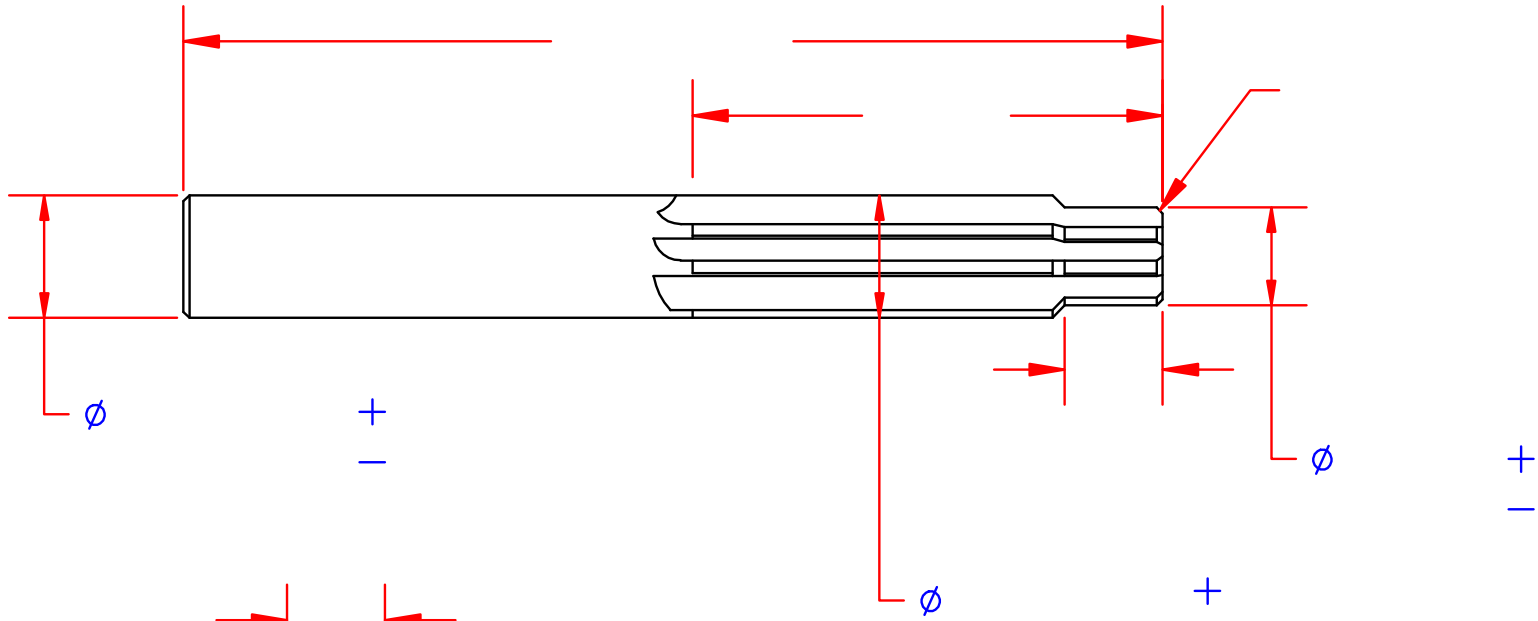

**COUGAR
CUTTING TOOLS, INC.**
 MAKERS OF SOLID CARBIDE
CUTTING TOOLS
 23520 REYNOLDS COURT
 CLINTON TOWNSHIP, MI 48036
 (586)469-1310 FAX (586)469-1314
 www.cougarct.com

*** COMPUTER GENERATED ***
 DRAWING
 DO NOT CHANGE MANUALLY

* DO NOT SCALE *
 * DRAWING *

CUSTOMER	
TOOL#	
DATE	SHEET A
DET. BY	CUT MATERIAL