

# OF FLUTES \_\_\_\_\_  
 HELIX ANGLE \_\_\_\_\_  
 HAND OF CUT \_\_\_\_\_  
 COATING \_\_\_\_\_  
 BACKTAPER \_\_\_\_\_

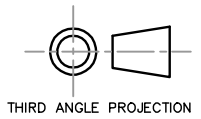

TANG YES NO  
 COOLANT THRU YES NO

STANDARD TOLERANCES UNLESS OTHERWISE SPECIFIED.	
0.00	±0.06
0.000	±0.005
0.0000	±0.0005
ANGLES	±2°

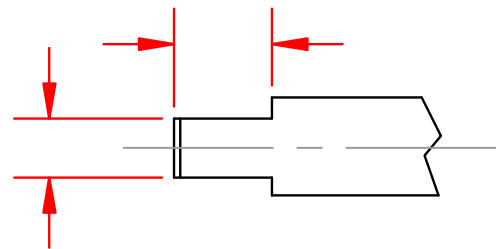
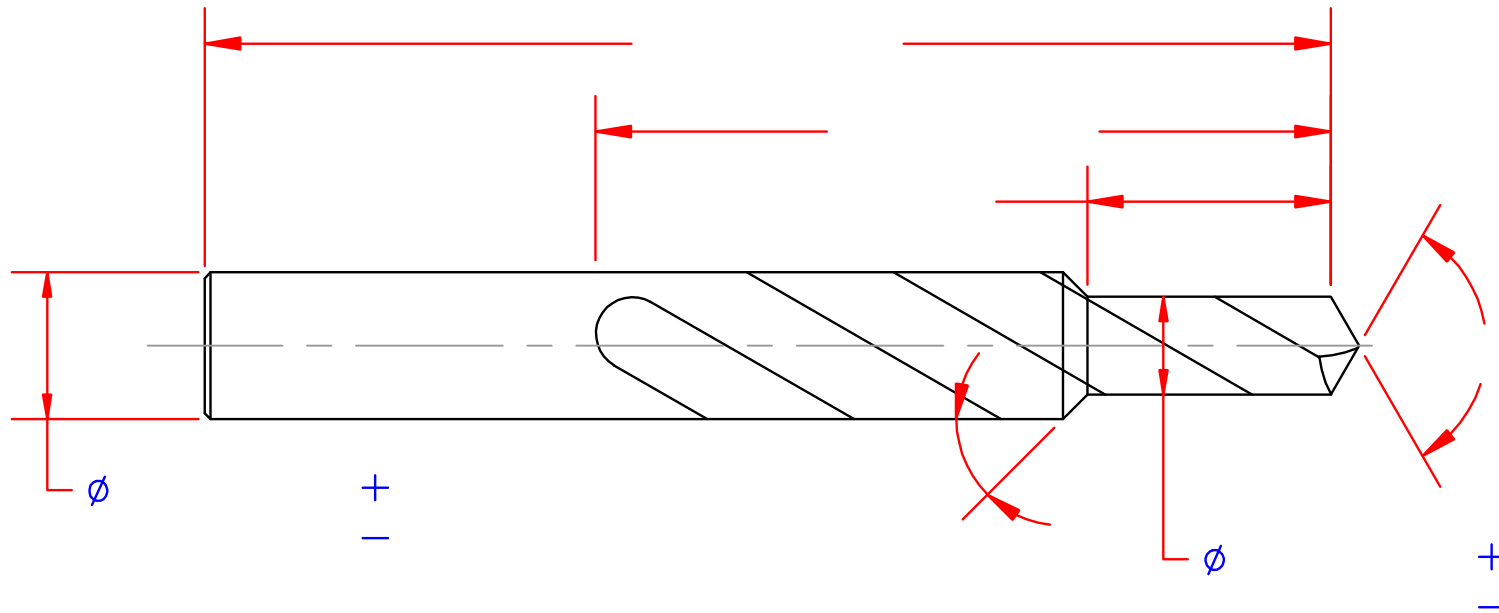

**COUGAR  
CUTTING TOOLS, INC.**  
 MAKERS OF SOLID CARBIDE  
CUTTING TOOLS  
 23520 REYNOLDS COURT  
 CLINTON TOWNSHIP, MI 48036  
 (586)469-1310 FAX (586)469-1314  
 www.cougarct.com

\*\*\* COMPUTER GENERATED \*\*\*  
 DRAWING  
 DO NOT CHANGE MANUALLY

\* DO NOT SCALE \*  
 \* DRAWING \*

CUSTOMER	
TOOL#	
DATE	SHEET A
DET. BY	CUT MATERIAL